

IKO Insulations UK Ltd

Pierson Road
The Enterprise Campus
Alconbury Weald
Huntingdon, PE28 4YA

Tel: 01480 274762

e-mail: info@enertherm.eu

website: www.enertherm.eu



Agrément Certificate

15/5283

Product Sheet 1

IKO INSULATIONS

IKO ENERTHERM ALU INSULATION BOARD FOR FLOORS

This Agrément Certificate Product Sheet⁽¹⁾ relates to IKO enertherm ALU Insulation Board for Floors, comprising a rigid polyisocyanurate (PIR) foam board with composite foil-facings, for use as insulation in ground-bearing or suspended concrete or timber ground-floors, and also with exposed, or semi-exposed, intermediate concrete or timber floors, in new or existing domestic and similar buildings.

(1) Hereinafter referred to as 'Certificate'.

CERTIFICATION INCLUDES:

- factors relating to compliance with Building Regulations where applicable
- factors relating to additional non-regulatory information where applicable
- independently verified technical specification
- assessment criteria and technical investigations
- design considerations
- installation guidance
- regular surveillance of production
- formal three-yearly review.

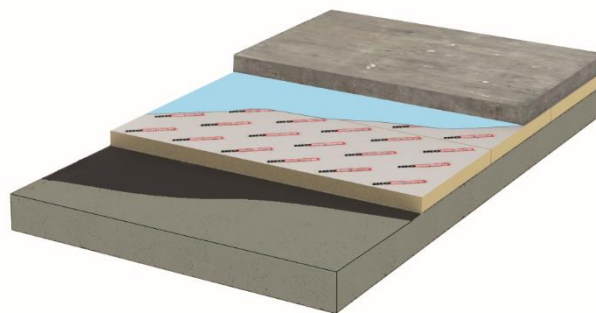

KEY FACTORS ASSESSED

Thermal performance — the product has a declared thermal conductivity (λ_D) of $0.022 \text{ W}\cdot\text{m}^{-1}\cdot\text{K}^{-1}$ (see section 6).

Condensation risk — the product can contribute to limiting the risk of condensation (see section 7).

Floor loading — the product, when installed in accordance with this Certificate, can support a design loading for domestic applications (see section 9).

Durability — the product will have a life equivalent to that of the floor structure in which it is incorporated (see section 12).



The BBA has awarded this Certificate to the company named above for the product described herein. This product has been assessed by the BBA as being fit for its intended use provided it is installed, used and maintained as set out in this Certificate.

On behalf of the British Board of Agrément

Date of Second issue: 28 April 2020

Originally certificated on 4 March 2016

Hardy Giesler
Chief Executive Officer

The BBA is a UKAS accredited certification body – Number 113.

The schedule of the current scope of accreditation for product certification is available in pdf format via the UKAS link on the BBA website at www.bbacerts.co.uk
Readers MUST check the validity and latest issue number of this Agrément Certificate by either referring to the BBA website or contacting the BBA directly.

Any photographs are for illustrative purposes only, do not constitute advice and should not be relied upon.

British Board of Agrément

Bucknalls Lane
Watford
Herts WD25 9BA

tel: 01923 665300
clientservices@bbacerts.co.uk
www.bbacerts.co.uk

©2020

Regulations

In the opinion of the BBA, IKO enertherm ALU Insulation Board for Floors, if installed, used and maintained in accordance with this Certificate, can satisfy or contribute to satisfying the relevant requirements of the following Building Regulations (the presence of a UK map indicates that the subject is related to the Building Regulations in the region or regions of the UK depicted):



The Building Regulations 2010 (England and Wales) (as amended)

Requirement:	A1	Loading
Comment:		The product can contribute to satisfying this Requirement. See section 9.2 of this Certificate.
Requirement:	C2(c)	Resistance to moisture
Comment:		The product can contribute to satisfying this Requirement. See sections 7.1 and 7.5 of this Certificate.
Requirement:	L1(a)(i)	Conservation of fuel and power
Comment:		The product can contribute to satisfying this Requirement. See sections 6.1 and 6.2 of this Certificate.
Regulation:	7(1)	Materials and workmanship
Comment:		The product is acceptable. See section 12 and the <i>Installation</i> part of this Certificate.
Regulation:	26	CO₂ emission rates for new buildings
Regulation:	26A	Fabric energy efficiency rates for new dwellings (applicable to England only)
Regulation:	26A	Primary energy consumption rates for new buildings (applicable to Wales only)
Regulation:	26B	Fabric performance values for new dwellings (applicable to Wales only)
Comment:		The product can contribute to satisfying these Regulations. See sections 6.1 and 6.2 of this Certificate.



The Building (Scotland) Regulations 2004 (as amended)

Regulation:	8(1)	Durability, workmanship and fitness of materials
Comment:		The product is acceptable. See section 12 and the <i>Installation</i> part of this Certificate.
Regulation:	9	Building standards applicable to construction
Standard:	1.1(b)	Structure
Comment:		The product can contribute to satisfying this Standard, with reference to clause 1.1.1 ⁽¹⁾ . See section 9.2 of this Certificate.
Standard:	3.15	Condensation
Comment:		The product can contribute to satisfying this Standard, with reference to clauses 3.15.1 ⁽¹⁾ , 3.15.4 ⁽¹⁾ and 3.15.5 ⁽¹⁾ . See sections 7.1 and 7.6 of this Certificate.
Standard:	6.1(b)	Carbon dioxide emissions
Standard:	6.2	Building insulation envelope
Comment:		The product can contribute to satisfying these Standards, with reference to clauses, or parts of, 6.1.1 ⁽¹⁾ , 6.1.6 ⁽¹⁾ , 6.2.1 ⁽¹⁾ , 6.2.3 ⁽¹⁾ , 6.2.4 ⁽¹⁾ , 6.2.5 ⁽¹⁾ , 6.2.6 ⁽¹⁾ , 6.2.7 ⁽¹⁾ , 6.2.9 ⁽¹⁾ , 6.2.10 ⁽¹⁾ , 6.2.11 ⁽¹⁾ and 6.2.13 ⁽¹⁾ . See sections 6.1 and 6.2 of this Certificate.
Standard:	7.1(a)(b)	Statement of sustainability
Comment:		The product can contribute to satisfying the relevant requirements of Regulation 9, Standards 1 to 6, and therefore will contribute to a construction meeting a bronze level of sustainability as defined in this Standard. In addition, the product can contribute to a construction meeting a higher level of sustainability as defined in this Standard, with reference to clauses 7.1.4 ⁽¹⁾ [Aspects 1 ⁽¹⁾ and 2 ⁽¹⁾], 7.1.6 ⁽¹⁾ [Aspects 1 ⁽¹⁾ and 2 ⁽¹⁾] and 7.1.7 ⁽¹⁾ [Aspect 1 ⁽¹⁾]. See section 6.1 of this Certificate.

Regulation:	12	Building standards applicable to conversions
Comment:		Comments made in relation to this product under Regulation 9, Standards 1 to 6, also apply to this Regulation, with reference to clause 0.12.1 ⁽¹⁾ and Schedule 6 ⁽¹⁾ .
		(1) Technical Handbook (Domestic)



The Building Regulations (Northern Ireland) 2012 (as amended)

Regulation:	23	Fitness of materials and workmanship
Comment:		The product is acceptable. See section 12 and the <i>Installation</i> part of this Certificate.
Regulation:	29	Condensation
Comment:		The product can contribute to satisfying this Regulation. See section 7.1 of this Certificate.
Regulation:	30	Stability
Comment:		The product can contribute to satisfying this Regulation. See section 9.2 of this Certificate.
Regulation:	39(a)(i)	Conservation measures
Regulation:	40(2)	Target carbon dioxide emission rate
Comment:		The product can contribute to satisfying these Regulations. See sections 6.1 and 6.2 of this Certificate.

Construction (Design and Management) Regulations 2015

Construction (Design and Management) Regulations (Northern Ireland) 2016

Information in this Certificate may assist the client, designer (including Principal Designer) and contractor (including Principal Contractor) to address their obligations under these Regulations.

See section: **3 Delivery and site handling (3.4)** of this Certificate.

Additional Information

NHBC Standards 2020

In the opinion of the BBA, IKO enertherm ALU Insulation Board for Floors, if installed and used in accordance with this Certificate, can satisfy or contribute to satisfying the relevant requirements in relation to *NHBC Standards*, Chapters 5.1 *Substructure and ground bearing floors* and 5.2 *Suspended ground floors*.

CE marking

The Certificate holder has taken the responsibility of CE marking the product in accordance with harmonised European Standard BS EN 13165 : 2012.

Technical Specification

1 Description

IKO enertherm ALU Insulation Board for Floors comprises a rigid polyisocyanurate (PIR) board with composite foil-facings. The boards have the nominal characteristics given in Table 1.

Table 1 Nominal characteristics

Size (mm)	1200 x 600 1200 x 1000 1200 x 2400
Thickness (mm)	30 to 140 (in 5 mm increments)
Edge detail	Square
Minimum compressive stress at 10% deformation (kPa)	175
Flatness (deviation from flatness – mm) (length ≤ 2.5 m) (area ≤ 0.75 m ²)	≤ 3
(length ≤ 2.5 m) (area > 0.75 m ²)	≤ 5
Foil-facings	Printed composite foil-facing both sides

2 Manufacture

2.1 IKO enertherm ALU Insulation Board for Floors is manufactured by blending together polyol and MDI in a continuous foaming process aided by a blowing agent and sandwiched between two composite foil-facings. After formation, the boards are left to cure and are cut to size.

2.2 As part of the assessment and ongoing surveillance of product quality, the BBA has:

- agreed with the manufacturer the quality control procedures and product testing to be undertaken
- assessed and agreed the quality control operated over batches of incoming materials
- monitored the production process and verified that it is in accordance with the documented process
- evaluated the process for management of nonconformities
- checked that equipment has been properly tested and calibrated
- undertaken to carry out the above measures on a regular basis through a surveillance process, to verify that the specifications and quality control operated by the manufacturer are being maintained.

3 Delivery and site handling

3.1 The product is delivered to site in polythene shrink-wrapped packs, incorporating a label with the Certificate holder's trade name, product description and characteristics, and the BBA logo incorporating the number of this Certificate.

3.2 The product must be protected from prolonged exposure to sunlight and should be stored either under cover or protected with opaque polythene sheeting. Where possible, packs should be stored inside. If outside, the product should be stacked flat, and raised above ground level and not in contact with ground moisture.

3.3 The product is light and easy to handle, and care should be exercised to avoid crushing the edges or corners. If damaged, the product should be discarded.

3.4 The product must not be exposed to open flame or other ignition sources, or to solvents or other chemicals.

Assessment and Technical Investigations

The following is a summary of the assessment and technical investigations carried out on IKO enertherm ALU Insulation Board for Floors.

Design Considerations

4 Use

4.1 IKO enertherm ALU Insulation Board for Floors is satisfactory for use as floor insulation and is effective in reducing the thermal transmittance (U value) of ground-bearing or suspended concrete ground-floors or timber ground-floors and also exposed or semi-exposed intermediate concrete or timber floors, in new and existing domestic or similar buildings. The product can also be used on suitably designed beam-and-block floors incorporating Type R2 semi-resisting or resisting blocks to BS EN 15037-2 : 2009 and self-bearing beams to BS EN 15037-1 : 2008.

4.2 Ground-bearing floors should only be used where the depth of compacted fill is less than 600 mm and is defined as non-shrinkable. Shrinkable fills are defined as material containing more than 35% fine particles (silt and clay) and with a plasticity Index of 10% or greater (shrinkable fills are susceptible to clay heave).

4.3 Ground-bearing concrete and suspended concrete ground-floors incorporating the product must include a suitable damp-proof membrane (dpm) laid beneath the insulation, in accordance with the relevant clauses of CP 102 : 1973, BS 8102 : 2009 and BS 8215 : 1991 (see section 13.5 of this Certificate).

4.4 Suspended concrete or timber ground-floors incorporating the insulation boards must include suitable ventilation of the sub-floor void (minimum 150 mm void between the underside of the floor and the ground surface) or a dpm. For suspended floors in locations where clay heave is anticipated, an additional void of up to 150 mm may be required to accommodate the possible expansion of the ground below the floor. In such cases where the risk of clay heave has been confirmed by geotechnical investigations by a competent individual, a total void of up to 300 mm may be required.

4.5 The overlay to the insulation boards should be:

- a vapour control layer (VCL) (see section 7.3)

and :

- a cement-based floor screed of minimum 65 mm thickness⁽¹⁾, laid in accordance with the relevant clauses of BS 8204-1 : 2003 and/or BS 8204-2 : 2003, and BS 8000-9 : 2003

or

- a wood-based floor [eg tongue-and-groove plywood to BS EN 636 : 2012, flooring grade particle board (Types P4 to P7) to BS EN 312 : 2010 or oriented strand board (OSB) of type OSB/3 or OSB/4 to BS EN 300 : 2006] of a suitable thickness to be determined by a suitably competent and experienced individual, installed in accordance with DD CEN/TR 12872 : 2014 and BS EN 12871 : 2013

or

- a concrete slab to BS EN 1992-1-1 : 2004.

(1) NHBC only accept ground-bearing floor slabs with at least 100 mm thick concrete including monolithic screed.

4.6 Where a concrete screed or slab finish is to be laid directly over the product, a polyethylene separating layer/VCL must be installed between the insulation and the concrete to prevent chemical attack and seepage between the boards (see section 13.7). Any gaps between insulation boards or around service openings, visible prior to installing the concrete, must be filled with expanding foam or strips of insulation.

4.7 Loadbearing internal walls must not be built on the insulation.

4.8 If present, mould or fungal growth should be treated prior to the application of this product.

5 Practicability of installation

The product is designed to be installed by a competent general builder, or a contractor, experienced with this type of product.

6 Thermal performance



6.1 Calculations of the thermal transmittance (U value) of a floor should be carried out in accordance with BS EN ISO 6946 : 2017, BS EN ISO 13370 : 2017 and BRE Report BR 443 : 2006 using the declared thermal conductivity (λ_D) value of $0.022 \text{ W}\cdot\text{m}^{-1}\cdot\text{K}^{-1}$ for the insulation, and an aged emissivity (ϵ) (to BS EN 15976 : 2011) of 0.9 for the printed foil-facings.

6.2 The U value of a completed floor will depend on the thickness of the product, the perimeter/area ratio and the floor type. Calculated U values for example constructions are given in Table 2.

Table 2 Example U values⁽¹⁾ — ground floor construction

Floor type	U value (W·m ⁻² ·K ⁻¹)	Insulation thickness (mm)				
		P/A ratio				
		0.2	0.4	0.6	0.8	1.0
Ground-bearing concrete floor ⁽¹⁾⁽⁴⁾	0.13	90	120	130	140	140
	0.15	70	100	110	115	120
	0.20	40	65	75	80	85
	0.22	30	55	65	70	75
	0.25	30	45	55	60	65
Suspended concrete ground-floor ⁽²⁾⁽⁴⁾	0.13	110	125	135	140	140
	0.15	85	105	120	115	120
	0.20	50	70	80	80	85
	0.22	45	60	70	70	75
	0.25	30	50	55	60	65
Suspended timber ground-floor ⁽³⁾	0.13	160 (80 and 80)	185 (100 and 85)	200 (100 and 100)	—	—
	0.15	125	155 (75 and 80)	165 (80 and 85)	170 (80 and 90)	175 (100 and 75)
	0.20	75	105	115	120	125
	0.22	60	90	100	105	110
	0.25	40	70	80	85	90

(1) Ground-bearing concrete floor construction (enertherm ALU insulation on top of slab, under screed finish) — 65 mm concrete screed $\lambda = 1.15 \text{ W}\cdot\text{m}^{-1}\cdot\text{K}^{-1}$, polyethylene separating layer, insulation, dpm, 100 mm concrete oversite, 150 mm sand blinded hardcore.

(2) Suspended concrete ground-floor construction (enertherm ALU insulation on top of beam-and-block, below screed finish) — 65 mm concrete screed $\lambda = 1.15 \text{ W}\cdot\text{m}^{-1}\cdot\text{K}^{-1}$, polyethylene separating layer, insulation, beam-and-block floor (12%) beam $\lambda = 2.00 \text{ W}\cdot\text{m}^{-1}\cdot\text{K}^{-1}$, dense block infill $\lambda = 1.13 \text{ W}\cdot\text{m}^{-1}\cdot\text{K}^{-1}$, ventilated void.

(3) Suspended timber ground-floor construction (enertherm ALU insulation between floor joists) — floor deck thermal resistance $0.169 \text{ m}^2\cdot\text{K}\cdot\text{W}^{-1}$, (based on 22 mm chipboard $\lambda = 0.13 \text{ W}\cdot\text{m}^{-1}\cdot\text{K}^{-1}$, insulation (87%) between 47 mm wide joists at 400 mm centres. The depth of the joists = 100, 150 or 200 mm depending on the depth of insulation between floor joists (11%), based on BRE Report BR 443 : 2006 (38 mm wide nogging every 3 metres).

(4) 30 mm edge insulation of Iko enertherm Alu at 65 mm deep.

Junctions

6.3 Care must be taken in the overall design and construction of junctions with other elements and openings to minimise thermal bridges and air infiltration. Detailed guidance can be found in the documents supporting the national Building Regulations.

7 Condensation risk

Interstitial condensation



7.1 Floors will adequately limit the risk of interstitial condensation when they are designed and constructed in accordance with BS 5250 : 2011 Annex F and the relevant guidance.

7.2 When the product is used above the dpm on a ground-bearing floor or suspended concrete floor, a VCL is installed on the warm side of the insulation to limit the risk of interstitial condensation, unless a risk assessment shows this is not necessary.

7.3 For suspended ground timber ground floors, it is not necessary to introduce a VCL if adequate sub-floor cross-ventilation is provided.

7.4 For the purposes of assessing the risk of interstitial condensation, the water vapour resistance of the foil facings may be taken as $1000 \text{ MN}\cdot\text{s}\cdot\text{g}^{-1}$ and the water vapour resistivity of the core may be taken as $183 \text{ MN}\cdot\text{s}\cdot\text{g}^{-1}\cdot\text{m}^{-1}$. The product, therefore, will provide a significant resistance to water vapour transmission.

Surface condensation



7.5 Floors will adequately limit the risk of surface condensation when the thermal transmittance (U value) does not exceed $0.7 \text{ W}\cdot\text{m}^{-2}\cdot\text{K}^{-1}$ at any point, and the junctions with walls are designed in accordance with section 6.3 of this Certificate.



7.6 In Scotland, floors will adequately limit the risk of surface condensation when the thermal transmittance (U value) does not exceed $1.2 \text{ W}\cdot\text{m}^{-2}\cdot\text{K}^{-1}$ at any point. Guidance may be obtained from BS 5250 : 2011 Annex F. Further guidance may be obtained from BRE Report BR 262 : 2002 and section 6.3 of this Certificate.

8 Behaviour in relation to fire

8.1 The product has a reaction to fire classification of Class E to BS EN 13501-1 : 2007⁽¹⁾.

(1) Warringtonfire report 19358D 20.09.2019. Copies can be obtained from the Certificate holder.

8.2 When properly installed, the product will not add significantly to any existing fire hazard. The product will be contained within the floor by the overlay, until the overlay itself is destroyed.

9 Floor loading

9.1 The compressive strength of the product (compressive stress at 10% deformation to BS EN 826 : 2013) is $\geq 175 \text{ kPa}$.



9.2 The product is suitable for domestic occupancies when covered with a suitable floor overlay (see section 4.5), and is capable of resisting a uniformly distributed load of $1.5 \text{ kN}\cdot\text{m}^{-2}$ or a concentrated load of 2 kN for category A1 and A2 (domestic) situations as defined in BS EN 1991-1-1 : 2002, National Annex Table NA.2. Further assessment by a suitably competent and experienced individual is necessary in the case of duty walkways and floors subject to physical activities.

9.3 The performance of the floor construction will depend on the insulation properties and type of floor overlay used (including thickness and strength). Where the product is used under a concrete slab, resistance to concentrated and distributed loads is a function of the slab specification. Further guidance on the suitability of floor overlays can be found in BS EN 13810-1 : 2002, DD CEN/TS 13810-2 : 2003, BS 8204-1 : 2003 and BS EN 312 : 2010, and from the flooring manufacturer.

10 Incorporation of services

10.1 De-rating of electrical cables should be considered where the insulation restricts air cooling of cables; the product must not be used in direct contact with electrical heating cables or hot water pipes. Where underfloor heating systems are to be used, the advice of the Certificate holder should be sought.

10.2 Where possible, electrical conduits, gas and water pipes or other services should be contained within ducts or channels within the concrete slab of ground bearing floors. Where this is not possible, the services may be accommodated within the insulation, provided they are securely fixed to the concrete slab. Electrical cables that are likely to come into contact with the insulation must be protected by a suitable conduit or PVC-U trunking. With hot pipes, the insulation must be cut back to maintain an air space.

10.3 Where water pipes are installed below the insulation, they must be pre-lagged with close-fitting pipe insulation. Pipes installed above the insulation will not require lagging, although some provision needs to be made for expansion and contraction.

10.4 Where the product is installed on a floor of a suspended beam-and-block design, all services must be installed in accordance with a BBA Certificate for that floor and/or with the relevant codes of practice.

10.5 To provide support for a particle board cover on overlay board floors where access to the services is desirable, a duct may be formed by mechanically fixing to the floor, timber bearers of the same thickness as the insulation. The duct should be as narrow as possible and not exceed 400 mm in width or the maximum particle board spans given in

DD CEN/TR 12872 : 2014 without intermediate support. Services should be suitably fixed to the floor base and not to the insulation boards (see section 6.3 regarding limiting heat loss).

10.6 On suspended timber ground floors, all the services should be incorporated beneath the existing floor, above the insulation if possible.

11 Maintenance

As the product is confined within the floor by the overlay and has suitable durability (see section 12), maintenance is not required.

12 Durability



The product is durable, rot-proof, dimensionally stable and, when installed with the overlays specified in this Certificate, will remain effective as an insulating material for the life of the building in which it is incorporated.

Installation

13 General

13.1 Installation of IKO enertherm ALU Insulation Board for Floors must be in accordance with the Certificate holder's installation instructions and the requirements of this Certificate.

13.2 Typical methods of installation are shown in Figures 1 to 4. Reference should also be made to BRE Report BR 262 : 2002.

Figure 1 Ground-bearing concrete floor – screed overlay

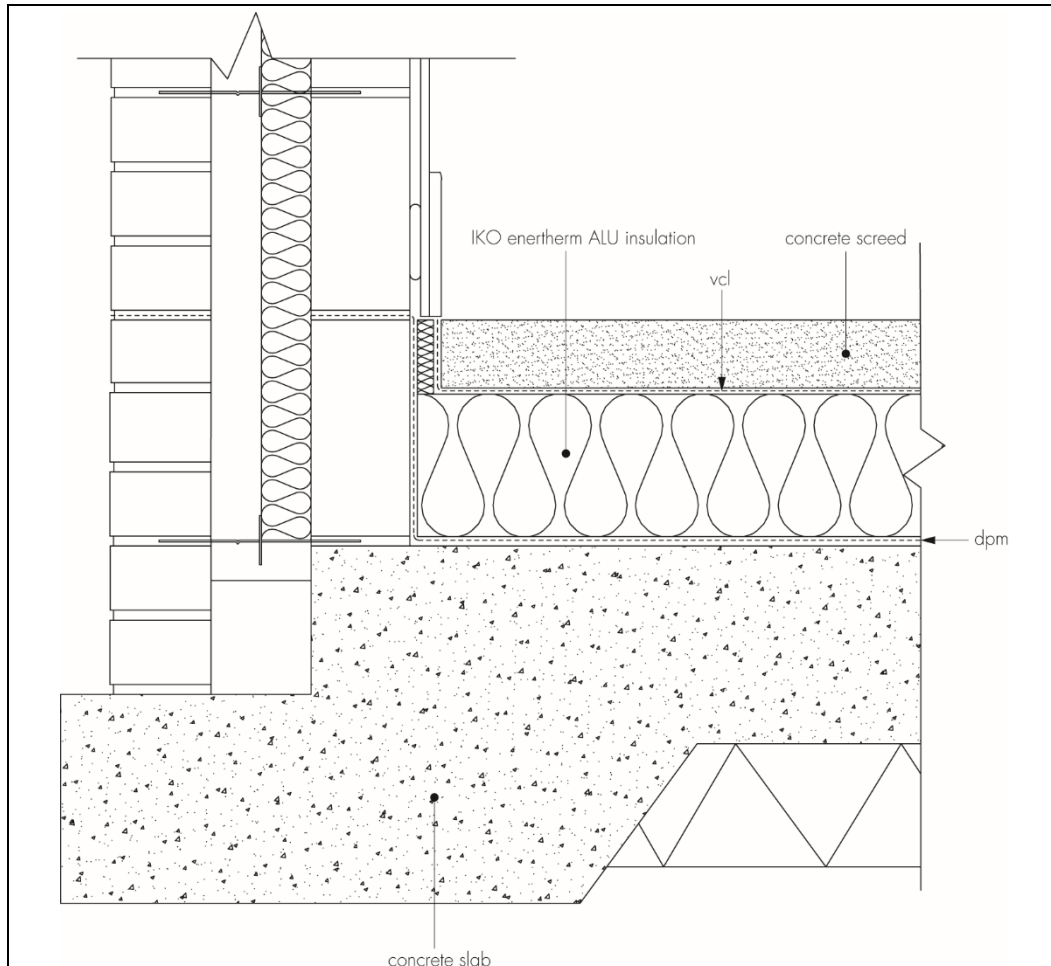

Figure 2 Ground-bearing concrete floor – concrete slab overlay

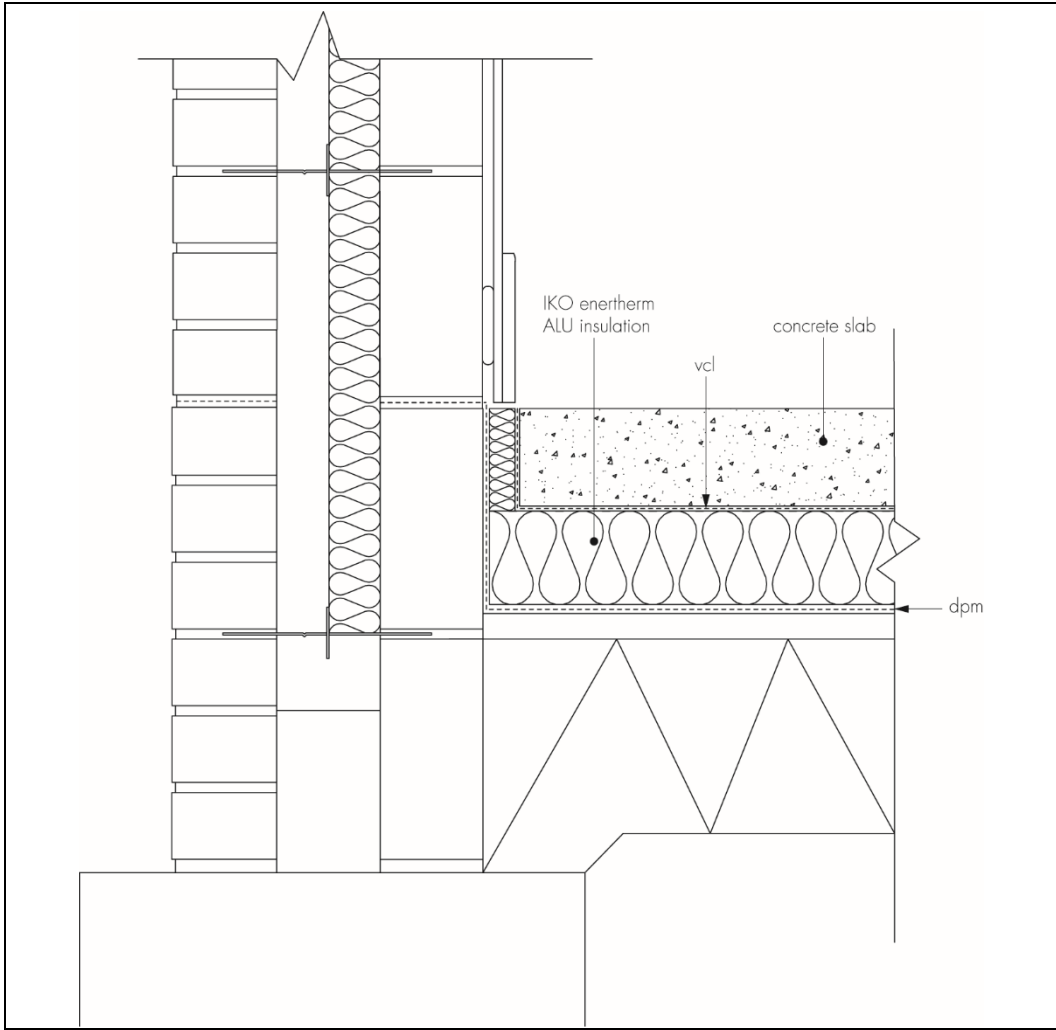

Figure 3 Suspended concrete beam-and-block floor – screed overlay

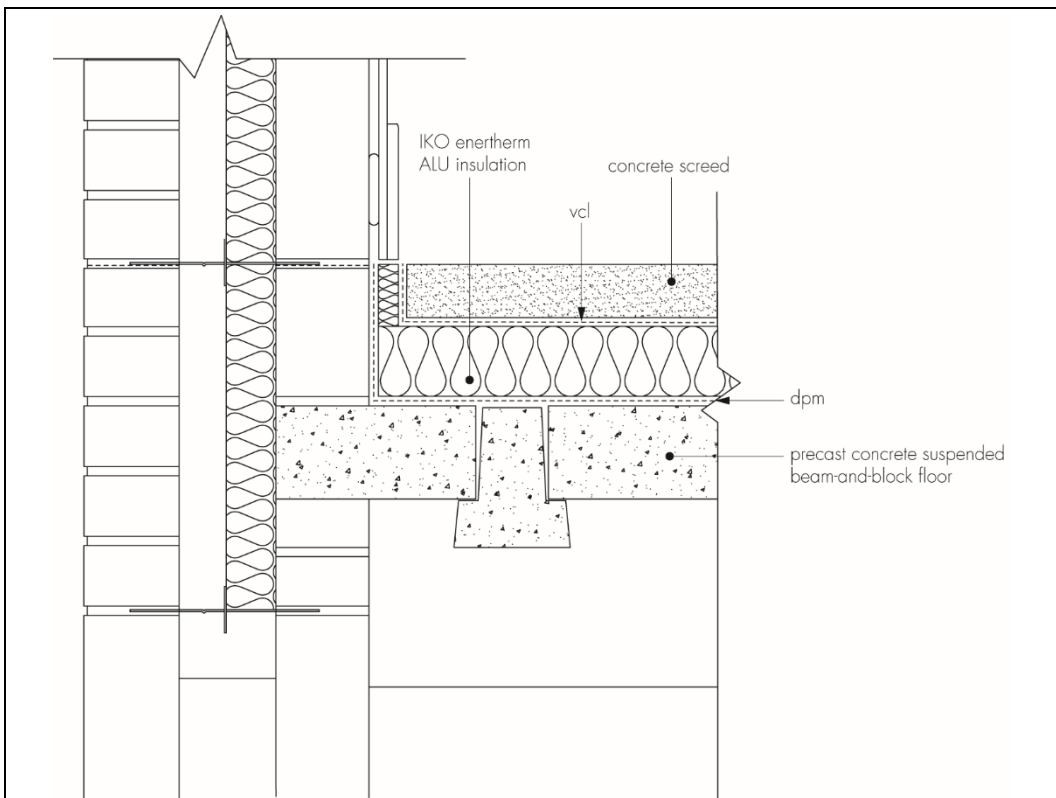
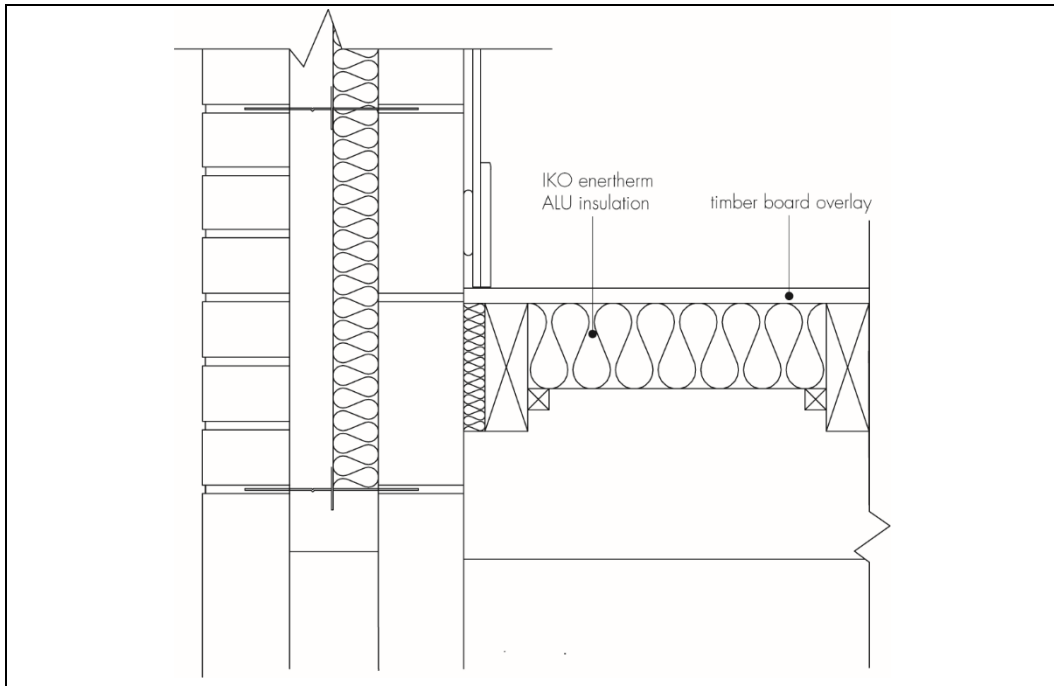

Figure 4 Suspended timber floor – board overlay



13.3 In ground-bearing concrete floors, the concrete floor slab over which the product is laid should be left for as long as possible to maximise drying out and dissipation of constructional moisture, in accordance with BS 8203 : 2017, Section 3.1.2.

13.4 The concrete floor surface should be smooth, level and flat to within 5 mm when measured with a two metre straight-edge. Irregularities greater than this must be removed. Minor irregularities (up to 10 mm deep) may be levelled with mortar or thin screed.

13.5 Where the insulation is used over ground-bearing concrete floor slabs, a suitable dpm in accordance with CP 102 : 1973 should be laid to resist moisture from the ground. If a liquid-type dpm is applied to the slab, it should be of a type compatible with the product and be allowed to dry out fully before the insulation is laid.

13.6 Where the insulation is used on hardcore bases beneath ground-bearing concrete slabs, the hardcore must be compacted and blinded with a thin layer of sand before application of the dpm, followed by the insulation boards.

13.7 A VCL is installed on the warm side of the insulation to inhibit the risk of interstitial condensation if necessary (see section 7.2). Where a concrete screed or slab finish is to be laid directly over the product, a polyethylene separating layer/VCL must be installed between the insulation and the concrete to prevent chemical attack and seepage between the boards.

13.8 Where a screed or concrete slab is laid over the insulation, vertical upstands of insulation should be provided and be of sufficient depth to fully separate the screed or slab from the wall. If used, a suitable cavity wall insulation material should be extended below the dpc level to provide edge insulation to the floor.

13.9 To limit the risk of damage from condensation and other sources of dampness, the product and overlays should only be laid after the construction is made substantially weathertight, eg after glazing. During construction, the product and overlay must be protected from damage by traffic and moisture sources such as water spillage and plaster droppings.

14 Procedure

14.1 The boards are cut to size (using a sharp knife or fine-toothed saw), as necessary, and laid with closely-butted, staggered cross-joints, ensuring that all spaces are completely filled.

14.2 The laying pattern should ensure that all cut edges are at the perimeter of the floor or some other feature, eg matwells, thresholds or access ducts. Spreader boards should be used to protect the insulation.

Cement-based screed overlay (Figures 1 and 3)

14.3 Perimeter edge pieces are cut and placed around the edges and taped at joints. A polyethylene VCL, at least 0.125 mm thick (500 gauge), is laid over the insulation. The VCL should have 150 mm overlaps, taped at the joints, and be turned up 100 mm at the walls. A properly compacted screed of a minimum 65 mm thickness is then laid over. The relevant clauses of BS 8204-1 : 2003 should be followed.

Concrete slab overlay (ground-bearing only) (Figure 2)

14.4 Perimeter edge pieces are cut and placed around the edges and taped at joints. A polyethylene VCL, at least 0.125 mm thick (500 gauge), is laid over the insulation. The VCL should have 150 mm overlaps, taped at the joints, and be turned up 100 mm at the walls. The concrete slab is laid to the required thickness in accordance with BS 8000-9 : 2003 and BS 8204-1 : 2003.

Timber based board overlay (Figure 4)

14.5 Before laying the plywood, particle board or OSB overlays, preservative-treated timber battens in accordance with BS 8417 : 2011 are positioned at doorways and access panels. Adequate time should be allowed for preservatives to be fixed and the solvents from solvent-based preservatives to evaporate.

14.6 Where the insulation is laid above a dpm, a polyethylene VCL of at least 0.125 mm (500 gauge) thickness is laid between the insulation and the timber board overlay. The VCL should have 150 mm overlaps, taped at the joints and turned up 100 mm at the walls.

14.7 Timber based overlay boards as specified in section 4.5, are laid with staggered cross-joints, in accordance with DD CEN/TR 12872 : 2014 and BS EN 12871 : 2013.

14.8 An expansion gap between the overlay board and the perimeter walls should be provided at a rate of 2 mm per metre run or a minimum of 10 mm, whichever is the greater.

14.9 Where there are long uninterrupted lengths of floor (eg corridors), proprietary expansion joints should be installed at intervals on the basis of a 2 mm gap per metre run of overlay board.

14.10 Before the overlay boards are interlocked, a waterproof PVA adhesive is applied to the joints.

14.11 Once the overlay board is laid, temporary wedges are inserted between the walls and the floor to maintain tight joints until the adhesive has set.

14.12 When the wedges are removed and before the skirting boards are fixed, a suitable compressible filler (eg foamed polyethylene) should be fitted around the perimeter of the floor between the overlay board and the walls.

14.13 Where there is a likelihood of regular water spillage in rooms (eg in kitchens, bathrooms, and shower and utility rooms), additional overlay board protection should be considered, eg a continuous flexible vinyl sheet flooring with welded joints, which is turned up at abutments and cove skirting.

Suspended timber floor (Figure 4)

14.14 Insulation boards can be supported between timber joists using saddle clips or timber beads. Where timber beads are used, a void may be incorporated above the insulation to accommodate services, if required.

14.15 Saddle clips are placed at intervals not exceeding 1 m along the timber floor joists. Where the product is to be installed on only one side of the joist, twin clips can be cut into single clips and nailed into place with galvanized nails.

14.16 If saddle clips are not used, the product may be retained using preservative-treated timber battens. The battens should be wide enough to retain the product in place and secured with corrosion-protected nails at a depth that will accommodate the thickness of the product.

14.17 The product should be cut to fit tightly between joists and pushed down onto the spikes of the saddle clips, or onto the beads. Small gaps should be insulated with cut strips of the product.

15 Tests

Results of tests were assessed to determine :

- thermal conductivity
- compressive stress at 10% deformation
- dimensional accuracy
- water vapour resistance
- diffusion-tight property of facings.

16 Investigations

16.1 Existing data on durability and properties in relation to fire were evaluated.

16.2 A calculation was undertaken to confirm the declared thermal conductivity (λ_D).

16.3 A series of U value calculations was carried out.

16.4 A condensation risk analysis was carried out.

16.5 The manufacturing process was evaluated, including the methods adopted for quality control, and details were obtained of the quality and composition of the materials used.

Bibliography

BS 5250 : 2011 + A1 : 2016 *Code of practice for control of condensation in buildings*

BS 8000-9 : 2003 *Workmanship on building sites — Cementitious levelling screeds and wearing screeds — Code of practice*

BS 8102 : 2009 *Code of practice for protection of below ground structures against water from the ground*

BS 8203 : 2017 *Code of practice for installation of resilient floor coverings*

BS 8204-1 : 2003 + A1 : 2009 *Screeds, bases and in-situ floorings — Concrete bases and cement sand levelling screeds to receive floorings — Code of practice*

BS 8204-2 : 2003 *Screeds, bases and in-situ floorings — Concrete wearing surfaces — Code of practice*

BS 8215 : 1991 *Code of practice for design and installation of damp-proof courses in masonry construction*

BS 8417 : 2011 + A1 : 2014 *Preservation of wood — Code of practice*

BS EN 300 : 2006 *Oriented Strand Boards (OSB) — Definitions, classification and specifications*

BS EN 312 : 2010 *Particleboards — Specifications*

BS EN 636 : 2012 + A1 : 2015 *Plywood — Specifications*

BS EN 826 : 2013 *Thermal insulating products for building applications — Determination of compression behaviour*

BS EN 1991-1-1 : 2002 *Eurocode 1 : Actions on structures — General actions — Densities, self-weight, imposed loads for buildings*

NA to BS EN 1991-1-1 : 2002 *UK National Annex to Eurocode 1 : Actions on structures — General actions — Densities, self-weight, imposed loads for buildings*

BS EN 1992-1-1 : 2004 + A1 : 2014 *Eurocode 2 : Design of concrete structures — General rules and rules for buildings*

BS EN 12871 : 2013 *Wood-based panels — Determination of performance characteristics for load bearing panels for use in floors, walls and roofs*

BS EN 13165 : 2012 + A2 : 2016 *Thermal insulation products for buildings — Factory made rigid polyurethane foam (PU) products — Specification*

BS EN 13501-1 : 2007 + A1 : 2009 *Fire classification of construction products and building elements — Classification using test data from reaction to fire tests*

BS EN 13810-1 : 2002 *Wood-based panels — Floating floors — Performance specifications and requirements*

BS EN 15037-1 : 2008 *Precast concrete products — Beam-and-block floor systems — Beams*

BS EN 15037-2 : 2009 + A1 : 2011 *Precast concrete products — Beam-and-block floor systems — Concrete blocks*

BS EN 15976 : 2011 *Flexible sheets for waterproofing. Determination of emissivity*

BS EN ISO 6946 : 2017 *Building components and building elements — Thermal resistance and thermal transmittance — Calculation method*

BS EN ISO 13370 : 2017 *Thermal performance of buildings — Heat transfer via the ground — Calculation methods*

CP 102 : 1973 *Code of practice for protection of buildings against water from the ground*

DD CEN/TR 12872 : 2014 *Wood-based panels — Guidance on the use of load-bearing boards in floors, walls and roofs*

DD CEN/TS 13810-2 : 2003 *Wood-based panels — Floating floors — Test methods*

BRE Report (BR 262 : 2002) *Thermal insulation: avoiding risks*

BRE Report (BR 443 : 2006) *Conventions for U-value calculations*

17 Conditions

17.1 This Certificate:

- relates only to the product/system that is named and described on the front page
- is issued only to the company, firm, organisation or person named on the front page – no other company, firm, organisation or person may hold or claim that this Certificate has been issued to them
- is valid only within the UK
- has to be read, considered and used as a whole document – it may be misleading and will be incomplete to be selective
- is copyright of the BBA
- is subject to English Law.

17.2 Publications, documents, specifications, legislation, regulations, standards and the like referenced in this Certificate are those that were current and/or deemed relevant by the BBA at the date of issue or reissue of this Certificate.

17.3 This Certificate will remain valid for an unlimited period provided that the product/system and its manufacture and/or fabrication, including all related and relevant parts and processes thereof:

- are maintained at or above the levels which have been assessed and found to be satisfactory by the BBA
- continue to be checked as and when deemed appropriate by the BBA under arrangements that it will determine
- are reviewed by the BBA as and when it considers appropriate.

17.4 The BBA has used due skill, care and diligence in preparing this Certificate, but no warranty is provided.

17.5 In issuing this Certificate the BBA is not responsible and is excluded from any liability to any company, firm, organisation or person, for any matters arising directly or indirectly from:

- the presence or absence of any patent, intellectual property or similar rights subsisting in the product/system or any other product/system
- the right of the Certificate holder to manufacture, supply, install, maintain or market the product/system
- actual installations of the product/system, including their nature, design, methods, performance, workmanship and maintenance
- any works and constructions in which the product/system is installed, including their nature, design, methods, performance, workmanship and maintenance
- any loss or damage, including personal injury, howsoever caused by the product/system, including its manufacture, supply, installation, use, maintenance and removal
- any claims by the manufacturer relating to CE marking.

17.6 Any information relating to the manufacture, supply, installation, use, maintenance and removal of this product/system which is contained or referred to in this Certificate is the minimum required to be met when the product/system is manufactured, supplied, installed, used, maintained and removed. It does not purport in any way to restate the requirements of the Health and Safety at Work etc. Act 1974, or of any other statutory, common law or other duty which may exist at the date of issue or reissue of this Certificate; nor is conformity with such information to be taken as satisfying the requirements of the 1974 Act or of any statutory, common law or other duty of care.

IKO Insulations UK

Appley Lane North
Appley Bridge
Wigan
Lancashire WN6 9AB

Tel: 01257 255771 Fax: 01257 252514

e-mail: info.uk@iko.com

website: www.ikogroup.co.uk



Agrément Certificate

15/5283

Product Sheet 3

IKO INSULATIONS

IKO ENERTHERM ALU INSULATION BOARD FOR FLAT ROOFS

This Agrément Certificate Product Sheet⁽¹⁾ relates to IKO enertherm ALU Insulation Board for Flat Roofs, comprising a rigid polyisocyanurate (PIR) foam board with composite foil-facings. The product is for use as a thermal insulation layer on limited access concrete, metal or timber flat roof decks. It is for use in conjunction with a vapour control layer and mechanically or adhesively fixed roof waterproofing systems, in domestic and non-domestic buildings.

(1) Hereinafter referred to as 'Certificate'.

CERTIFICATION INCLUDES:

- factors relating to compliance with Building Regulations where applicable
- factors relating to additional non-regulatory information where applicable
- independently verified technical specification
- assessment criteria and technical investigations
- design considerations
- installation guidance
- regular surveillance of production

KEY FACTORS ASSESSED

Thermal performance — the product has a declared thermal conductivity* (λ_D) of $0.022 \text{ W}\cdot\text{m}^{-1}\cdot\text{K}^{-1}$ (see section 6).

Condensation risk — the product can contribute to limiting the risk of condensation (see section 7).

Strength and stability — when installed on suitable substrates using appropriate fixing methods, the product can adequately transfer maintenance traffic loads and wind loads to the roof deck (see section 8).

Behaviour in relation to fire — the product has a reaction to fire classification* of Class E in accordance with BS EN 13501-1 : 2007 (see section 9).

Durability — the product is durable, rot proof, water resistant and sufficiently stable to remain effective as an insulation for the life of the building (see section 11).

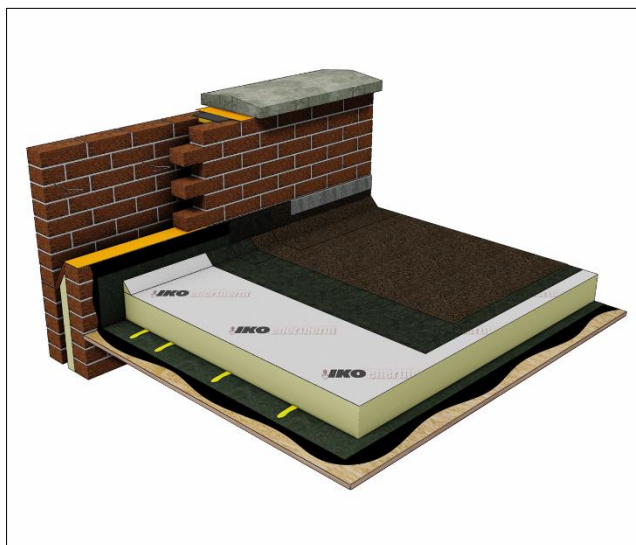

The BBA has awarded this Certificate to the company named above for the product described herein. This product has been assessed by the BBA as being fit for its intended use provided it is installed, used and maintained as set out in this Certificate.

On behalf of the British Board of Agrément

Date of First issue: 4 March 2016

John Albon – Head of Approvals
Construction Products

Claire Curtis-Thomas
Chief Executive

The BBA is a UKAS accredited certification body – Number 113.

The schedule of the current scope of accreditation for product certification is available in pdf format via the UKAS link on the BBA website at www.bbacerfs.co.uk
Readers are advised to check the validity and latest issue number of this Agrément Certificate by either referring to the BBA website or contacting the BBA direct.

British Board of Agrément

Bucknalls Lane
Watford
Herts WD25 9BA

tel: 01923 665300

fax: 01923 665301

clientservices@bba.star.co.uk

www.bbacerfs.co.uk

©2016

Regulations

In the opinion of the BBA, IKO enertherm ALU Insulation Board for Flat Roofs, if installed, used and maintained in accordance with this Certificate, can satisfy or contribute to satisfying the relevant requirements of the following Building Regulations (the presence of a UK map indicates that the subject is related to the Building Regulations in the region or regions of the UK depicted):



The Building Regulations 2010 (England and Wales) (as amended)

Requirement:	A1	Loading
Comment:		The product can contribute to satisfying this Requirement. See sections 8.1 and 8.2 of this Certificate.
Requirement:	B4(2)	External fire spread
Comment:		Roofs incorporating the product can satisfy this Requirement. See section 9.3 of this Certificate.
Requirement:	C2(c)	Resistance to moisture
Comment:		The product can contribute to satisfying this Requirement. See sections 7.1 and 7.4 of this Certificate.
Requirement:	L1(a)(i)	Conservation of fuel and power
Comment:		The product can contribute to satisfying this Requirement. See section 6 of this Certificate.
Regulation:	7	Materials and workmanship
Comment:		The product is acceptable. See section 11.1 and the <i>Installation</i> part of this Certificate.
Regulation:	26	CO₂ emission rates for new buildings
Regulation:	26A	Fabric energy efficiency rates for new dwellings (applicable to England only)
Regulation:	26A	Primary energy consumption rates for new buildings (applicable to Wales only)
Regulation:	26B	Fabric performance values for new dwellings (applicable to Wales only)
Comment:		The product can contribute to satisfying these Regulations. See section 6 of this Certificate.



The Building (Scotland) Regulations 2004 (as amended)

Regulation:	8(1)	Durability, workmanship and fitness of materials
Comment:		The product is acceptable. See section 11.1 and the <i>Installation</i> part of this Certificate.
Regulation:	9	Building standards applicable to construction
Standard:	1.1	Structure
Comment:		The product can contribute to satisfying this standard, with reference to clauses 1.1.1 ⁽¹⁾⁽²⁾ , 1.1.2 ⁽¹⁾⁽²⁾ and 1.1.3 ⁽¹⁾⁽²⁾ . See sections 8.1 and 8.2 of this Certificate.
Standard:	2.8	Spread from neighbouring buildings
Comment:		Roofs incorporating the product can satisfy this Standard, with reference to clause 2.8.1 ⁽¹⁾⁽²⁾ . See section 9.3 of this Certificate.
Standard:	3.15	Condensation
Comment:		The product can contribute to a roof satisfying this Standard, with reference to clauses 3.15.1 ⁽¹⁾⁽²⁾ , 3.15.4 ⁽¹⁾⁽²⁾ and 3.15.5 ⁽¹⁾⁽²⁾ . See sections 7.1 and 7.5 of this Certificate.
Standard:	6.1(b)	Carbon dioxide emissions
Standard:	6.2	Building insulation envelope
Comment:		The product can contribute to satisfying these Standards, with reference to clauses, or parts of, 6.1.1 ⁽¹⁾ , 6.1.2 ⁽²⁾ , 6.1.6 ⁽¹⁾ , 6.2.1 ⁽¹⁾⁽²⁾ , 6.2.3 ⁽¹⁾ , 6.2.4 ⁽²⁾ , 6.2.5 ⁽²⁾ , 6.2.6 ⁽¹⁾ , 6.2.7 ⁽¹⁾ , 6.2.8 ⁽¹⁾⁽²⁾ , 6.2.9 ⁽¹⁾⁽²⁾ , 6.2.10 ⁽¹⁾⁽²⁾ , 6.2.11 ⁽¹⁾⁽²⁾ , 6.2.12 ⁽²⁾ and 6.2.13 ⁽¹⁾⁽²⁾ . See sections 6.1 and 6.2 of this Certificate.

Standard:	7.1(a)(b)	Statement of sustainability
Comment:		The product can contribute to satisfying the relevant requirements of Regulation 9, Standards 1 to 6, and therefore will contribute to a construction meeting a bronze level of sustainability as defined in this Standard. In addition, the product can contribute to a construction meeting a higher level of sustainability as defined in this Standard, with reference to clauses 7.1.4 ⁽¹⁾⁽²⁾ [Aspects 1 ⁽¹⁾⁽²⁾ and 2 ⁽¹⁾], 7.1.6 ⁽¹⁾⁽²⁾ [Aspects 1 ⁽¹⁾⁽²⁾ and 2 ⁽¹⁾] and 7.1.7 ⁽¹⁾⁽²⁾ [Aspect 1 ⁽¹⁾⁽²⁾]. See section 6 of this Certificate.
Regulation:	12	Building standards applicable to conversions
Comment:		Comments made in relation to this product under Regulation 9, Standards 1 to 6, also apply to this Regulation, with reference to clause 0.12.1 ⁽¹⁾⁽²⁾ and Schedule 6 ⁽¹⁾⁽²⁾ .
		(1) Technical Handbook (Domestic) (2) Technical Handbook (Non-Domestic).



The Building Regulations (Northern Ireland) 2012 (as amended)

Regulation:	23	Fitness of materials and workmanship
Comment:		The product is acceptable. See section 11.1 and the <i>Installation</i> part of this Certificate.
Regulation:	29	Condensation
Comment:		The product can contribute to satisfying this Regulation. See section 7.1 of this Certificate.
Regulation:	30	Stability
Comment:		The product can contribute to satisfying this Regulation. See sections 8.1 and 8.2 of this Certificate.
Regulation:	36(b)	External fire spread
Comment:		Roofs incorporating the product can satisfy this Regulation. See section 9.3 of this Certificate.
Regulation:	39(a)(i)	Conservation measures
Regulation:	40(2)	Target carbon dioxide emission rate
Comment:		Roofs incorporating the product can satisfy these Regulations. See section 6 of this Certificate.

Construction (Design and Management) Regulations 2015

Construction (Design and Management) Regulations (Northern Ireland) 2007

Information in this Certificate may assist the client, Principal Designer/CDM co-ordinator, designer and contractors to address their obligations under these Regulations.

See section: **3 Delivery and site handling (3.4)** of this Certificate.

Additional Information

NHBC Standards 2016

NHBC accepts the use of IKO enertherm ALU Insulation Board for Flat Roofs, provided it is installed, used and maintained in accordance with this Certificate, in relation to *NHBC Standards*, Chapter 7.1 *Flat roofs and balconies*.

CE marking

The Certificate holder has taken the responsibility of CE marking the product in accordance with harmonised European Standard BS EN 13165 : 2012. An asterisk (*) appearing in this Certificate indicates that data shown is given in the manufacturer's Declaration of Performance.

Technical Specification

1 Description

1.1 IKO enertherm ALU Insulation Board for Flat Roofs comprises a rigid polyisocyanurate (PIR) board with composite foil-facings on both sides.

1.2 The product has the nominal characteristics as shown in Table 1.

Table 1 Nominal characteristics

Size (mm)	1200 x 600 1200 x 1000 1200 x 2400
Thickness (mm)	30, 40, 50, 60, 70, 75, 80, 90, 100, 110, 120 and 140
Edge detail	Plain square edge
Minimum compressive stress at 10% deformation (kPa)*	175
Foil-facings	Printed composite foil-facing both sides

1.3 The product is installed as part of a flat roof system in conjunction with the following items (which are outside the scope of this Certificate):

- waterproofing membrane/system
- vapour control layer (VCL)
- mechanical and adhesive fixing systems.

2 Manufacture

2.1 IKO enertherm ALU Insulation Board for Flat Roofs is manufactured by blending together polyol and MDI in a continuous foaming process aided by a blowing agent, and sandwiched between two composite foil-facings. After formation, the boards are left to cure and are cut to size.

2.2 As part of the assessment and ongoing surveillance of product quality, the BBA has:

- agreed with the manufacturer the quality control procedures and product testing to be undertaken
- assessed and agreed the quality control operated over batches of incoming materials
- monitored the production process and verified that it is in accordance with the documented process
- evaluated the process for management of nonconformities
- checked that equipment has been properly tested and calibrated
- undertaken to carry out the above measures on a regular basis through a surveillance process, to verify that the specifications and quality control operated by the manufacturer are being maintained.

2.3 The management system of the manufacturer has been assessed and registered as meeting the requirements of BS EN ISO 14001 : 2004 by Stichting QualityMasters (Certificate NL 6397uk).

3 Delivery and site handling

3.1 The product is delivered to site in packs, wrapped in polythene. Each pack of boards contains a label with the manufacturer's trade name, product description, board dimensions, and the BBA logo incorporating the number of this Certificate.

3.2 The product must be protected from prolonged exposure to sunlight, and should be stored under cover or protected with opaque polythene sheeting. Where possible, packs should be stored inside. If stored outside, the product should be stacked flat, and raised above ground level and not in contact with ground moisture.

3.3 The product is light and easy to handle and care should be exercised to avoid crushing the edges or corners. If damaged the product should be discarded.

3.4 The product must not be exposed to open flame or other ignition sources, or to solvents or other chemicals.

Assessment and Technical Investigations

The following is a summary of the assessment and technical investigations carried out on IKO enertherm ALU Insulation Board for Flat Roofs.

Design Considerations

4 Use

4.1 IKO enertherm ALU Insulation Board for Flat Roofs is suitable for use as flat roof insulation and is effective in reducing the thermal transmittance (U value) of concrete, metal or timber flat roofs, with access limited to maintenance only (see section 4.5).

4.2 Decks should be designed in accordance with the relevant clauses of either BS 6229 : 2003 or BS EN 13956 : 2012 and, where appropriate, the *NHBC Standards* 2016, Chapter 7.1.

4.3 Roofs should incorporate a VCL below the product which is compatible with both the product and the waterproofing system. Advice should be sought from the Certificate holder.

4.4 The product is for use with one of the following waterproofing specifications:

- built-up specifications including reinforced bitumen membranes to BS 8747 : 2007 in accordance with the recommendations of Table 5, and installed to the relevant clauses of BS 8217 : 2005
- single ply membranes, which are the subject of a current Agrément Certificate, laid in accordance with the requirements of that Certificate, and the manufacturer's recommendations
- other waterproofing systems, including liquid-applied waterproofing, which are the subject of a current Agrément Certificate, laid in accordance with, and within the limitations imposed by, that Certificate.

4.5 Limited access roofs are defined for the purpose of this Certificate as those roofs subject only to pedestrian traffic for maintenance of the roof covering, cleaning of gutters, etc.

4.6 Flat roofs are defined for the purpose of this Certificate as those roofs having a minimum finished fall of 1:80 and a maximum 1:6 as defined in BS 6229 : 2003.

4.7 For design purposes on flat roofs, twice the minimum finished fall should be assumed, unless a detailed analysis of the roof is available, including overall and local deflections, direction of falls etc.

5 Practicability of installation

The product is designed to be installed by a competent general builder, or a contractor, experienced with this type of product.

6 Thermal performance



6.1 Calculations of thermal transmittance (U value), should be carried out in accordance with BS EN ISO 6946 : 2007 and BRE Report BR 443 : 2006, using the declared thermal conductivity (λ_D)* of $0.022 \text{ W}\cdot\text{m}^{-1}\cdot\text{K}^{-1}$ for the insulation.

6.2 The U value of a completed roof will depend on the thickness of insulation used, the number and type of fixings and the insulating value of other roof components/layers. Example U values of roofs incorporating the product are shown in Table 2.

Table 2 Example U values – flat roofs

U value ($W \cdot m^{-2} \cdot K^{-1}$)	Insulation Thickness ⁽¹⁾ (mm) ⁽¹⁾		
	Concrete ⁽²⁾⁽⁵⁾	Timber ⁽³⁾⁽⁵⁾	Metal ⁽⁴⁾⁽⁵⁾
0.13	160 (80 + 80)	155 (80 + 75)	165 (90 + 75)
0.15	140	140	140
0.16	140	140	140
0.18	120	110	120
0.20	110	100	110
0.25	90	75	90

(1) Nearest available thickness.

(2) 150 mm concrete deck — $1.33 W \cdot m^{-2} \cdot K^{-1}$, VCL, insulation, mechanically fixed single-ply waterproofing membrane.

(3) 12.5 mm plasterboard, 150 mm timber joists (12.5%)/air cavity (87.5%), 18 mm plywood decking, VCL, insulation, mechanically fixed single-ply waterproofing membrane.

(4) Metal deck, VCL, insulation, mechanically fixed single-ply waterproofing membrane.

(5) Thermally broken tube fixings installed – therefore no fixing correction applied.

Junctions

6.3 Care must be taken in the overall design and construction of junctions with other elements and openings to minimise thermal bridges and air infiltration. Detailed guidance can be found in the documents supporting the national Building Regulations.

7 Condensation risk

Interstitial condensation



7.1 Roofs will adequately limit the risk of interstitial condensation when they are designed and constructed in accordance with BS 5250 : 2011, Annexes D and H and the relevant guidance.

7.2 The foil-facings have a water vapour resistance of $1000 MN \cdot s \cdot g^{-1}$ and the insulation core has a water vapour resistivity of approximately $183 MN \cdot s \cdot g^{-1} \cdot m^{-1}$. The product, therefore, will provide a significant resistance to water vapour transmission.

7.3 To minimise moisture entering the roof, a VCL should be used with sealed and lapped joints and be turned up around the insulation and bonded to the waterproofing finish.

Surface condensation



7.4 Roofs will adequately limit the risk of surface condensation when the thermal transmittance (U value) does not exceed $0.35 W \cdot m^{-2} \cdot K^{-1}$ at any point, and the junctions with other elements are designed in accordance with the guidance referred to in section 6.3 of this Certificate.



7.5 For buildings in Scotland, constructions will be acceptable where the thermal transmittance (U value) does not exceed $1.2 W \cdot m^{-2} \cdot K^{-1}$ at any point, and the junctions with other elements are designed in accordance with the guidance referred to in BS 5250 : 2011, Annex H. Further guidance may be obtained from BRE Report BR 262 : 2002 and section 6.3 of this Certificate.

8 Strength and stability



8.1 When installed on suitable flat roof decks, using appropriate mechanical fixings, the product can adequately transfer maintenance traffic loads and negative and positive (suction and pressure) wind loads to the roof deck.

8.2 When adhesively fixed, adhesion between the insulation board component and VCL, and between the boards and overlay, is adequate to resist the effects of wind suction and thermal cycling likely to be experienced under normal conditions. Metal deck profiles should give a bonding area of at least 33% of the total projected surface area. In areas where high wind speeds can be expected, mechanical fixing should be considered, and the advice of the Certificate holder should be sought as to the method of fixing. Reference should be made to BS EN 1991-1-4 : 2005 where a calculation is required for a specific building project.

8.3 The roof construction must be structurally sound and have sufficient strength and stability to resist all dead, imposed and wind loads. It must also have adequate resistance to the pull-out forces created by the wind forces acting on the specified fixings used.

8.4 The suitability of the substrate to accept the mechanical fixings or adhesive bond must be established before installation. Mechanical fixings must be checked before installation by carrying out in-situ pull-out or pull-through testing to determine the maximum safe working load the fixings can resist. The advice of the Certificate holder should be sought with respect to suitable mechanical fixings.

8.5 All design analysis must be in accordance with British or European Standards relevant to the construction. The requirement for fixings to suit the wind uplift requirements for the particular site should be assessed in accordance with BS EN 1991-1-4 : 2005. All calculations should be carried out by a suitably competent and experienced individual.

8.6 The number and type of mechanical fixings required will vary depending on the geographical location of the building, topographical data and height and width of the roof concerned etc, and the Certificate holder's advice should be sought in this respect.

8.7 Each fixing must incorporate a minimum 75 mm diameter thermally broken tube washer, which must not retain more than one board.

8.8 Roof waterproofing systems (see section 4.4 for suitable types) must be applied in accordance with the relevant Agrément Certificates and manufacturers' instructions.

8.9 The product has not been assessed for use with permanent distributed or concentrated loads, such as air conditioning units, mechanical plants, water tanks, etc. Such loads should be supported directly on the roof construction. The product is not suitable for use when permanent roof access is required.

8.10 When profiled decking is used, the product will need to span across the ribs. Maximum permissible spans between ribs for the different product thicknesses are shown in Table 3.

Table 3 Maximum clear span

Maximum clear span (mm)		Minimum roofboard thickness (mm)
< 75		25
> 75	≤ 100	30
> 100	≤ 125	35
> 125	≤ 150	40
> 150	≤ 175	45
> 175	≤ 200	50
> 200	≤ 225	55
> 225	≤ 250	60

8.11 When maintenance of the roof waterproofing is required, protective boarding should be laid over the roof surface to avoid concentrations of load.

9 Behaviour in relation to fire

9.1 The product has a reaction to fire classification* of Class E in accordance with BS EN 13501-1 : 2007.

9.2 The fire rating of any roof containing the product will depend on the type of deck and the nature of the roof waterproofing.



9.3 When classified in accordance with BS EN 13501-5 : 2005, a system comprising a 0.7 mm trapezoidal steel deck, a 2 mm self-adhesive Systems S-A vapour control layer, a 130 mm PIR enertherm insulation bonded with IKOpro High Performance PU adhesive, and a layer of Armourplan PSG, fully bonded with Spectrabond Low Foaming PU adhesive, achieved a B_{ROOF} (t4) rating.

9.4 The designation of other specifications should be confirmed by:

England and Wales — test or assessment in accordance with Approved Document B, Appendix A, clause A1

Scotland — test to conform to Mandatory Standard 2.8, clause 2.8.1⁽¹⁾⁽²⁾

(1) Technical Handbook (Domestic).

(2) Technical Handbook (Non-Domestic).

Northern Ireland — test or assessment by a UKAS-accredited laboratory, BRE or an independent consultant with appropriate experience.

10 Maintenance

The product, once installed, does not require any regular maintenance of the insulation layer and has suitable durability provided the roof waterproofing is inspected and maintained at regular intervals (see section 11).

11 Durability



11.1 The product is durable, rot proof, water resistant and sufficiently stable to remain effective as an insulation for the life of the building.

11.2 When the waterproof covering is renewed at a later date, the insulation will remain suitable for continued use, provided it is undamaged by replacement of the waterproof covering.

Installation

12 General

12.1 IKO enertherm ALU Insulation Board for Flat Roofs must be installed in accordance with the Certificate holder's instructions, BS 6229 : 2003, BS 8217 : 2005, BS EN 13956 : 2012 and the relevant Agrément Certificate (where applicable), depending on the waterproofing to be applied.

12.2 Care should be taken to ensure the deck is graded to the correct fall, and is dry, clean and free from any projections or gaps.

12.3 Any hollows, depressions or backfalls found in the roof deck must be rectified prior to laying the insulation.

12.4 For both mechanically and adhesively fixed systems, the suitability of the substrate deck to accept adhesive bond or mechanical fixings must be checked prior to the work commencing.

12.5 The deck to which the VCL is to be applied must be even, dry, sound, free from dust and grease and other defects which may impair the bond.

12.6 On multi-storey buildings or in areas subject to high wind loads, additional mechanical fixings may be required and the advice of the Certificate holder should be sought on any limitations of use.

12.7 The mechanical fixing frequency and pattern should be predetermined in accordance with the Certificate holder's instructions and the relevant clauses of BS EN 1991-1-4 : 2005.

12.8 To prevent moisture being trapped on or in the insulation it is essential to:

- protect the product during laying, before the application of the roof waterproofing, or to lay the roof covering at the same time as laying the product. If the product is accidentally wetted, it must be replaced
- install the product only when the ambient temperature is above 5°C, to prevent condensation.

12.9 The product can be cut with a sharp knife or fine-toothed saw to fit around projections through the roof.

12.10 Once installed, access to the roof should be restricted in accordance with section 4.5.

13 Procedure

Concrete/Metal and Timber Decks

Mechanically fastened roofing system applications

13.1 A 0.25 mm (minimum) thick polyethylene VCL should be laid, with 80 mm (minimum) sealed laps. The VCL should be turned up around the insulation and sealed to the waterproof finish at all edges and penetrations such as rooflights. Advice may be sought from the Certificate holder.

13.2 The product is laid over the VCL in a break-bonded pattern. On profiled metal decks, the long edges of the board should be laid at right angles to the ribs and all board ends must be fully supported on a rib. Boards are secured to the deck with a minimum of four mechanical fixings for 1200 mm by 1000 mm and 1200 mm by 600 mm boards, or six mechanical fixings for 2400 mm by 1200 mm boards. See Figure 1 for minimum fixing layout.

13.3 The waterproofing membrane (polymeric or bituminous) is mechanically fixed to the deck through the product, with joints overlapped prior to sealing of the joint, in accordance with the manufacturer's instructions and the relevant Agrément Certificate.

Figure 1 — Minimum fixing layout for the different board sizes

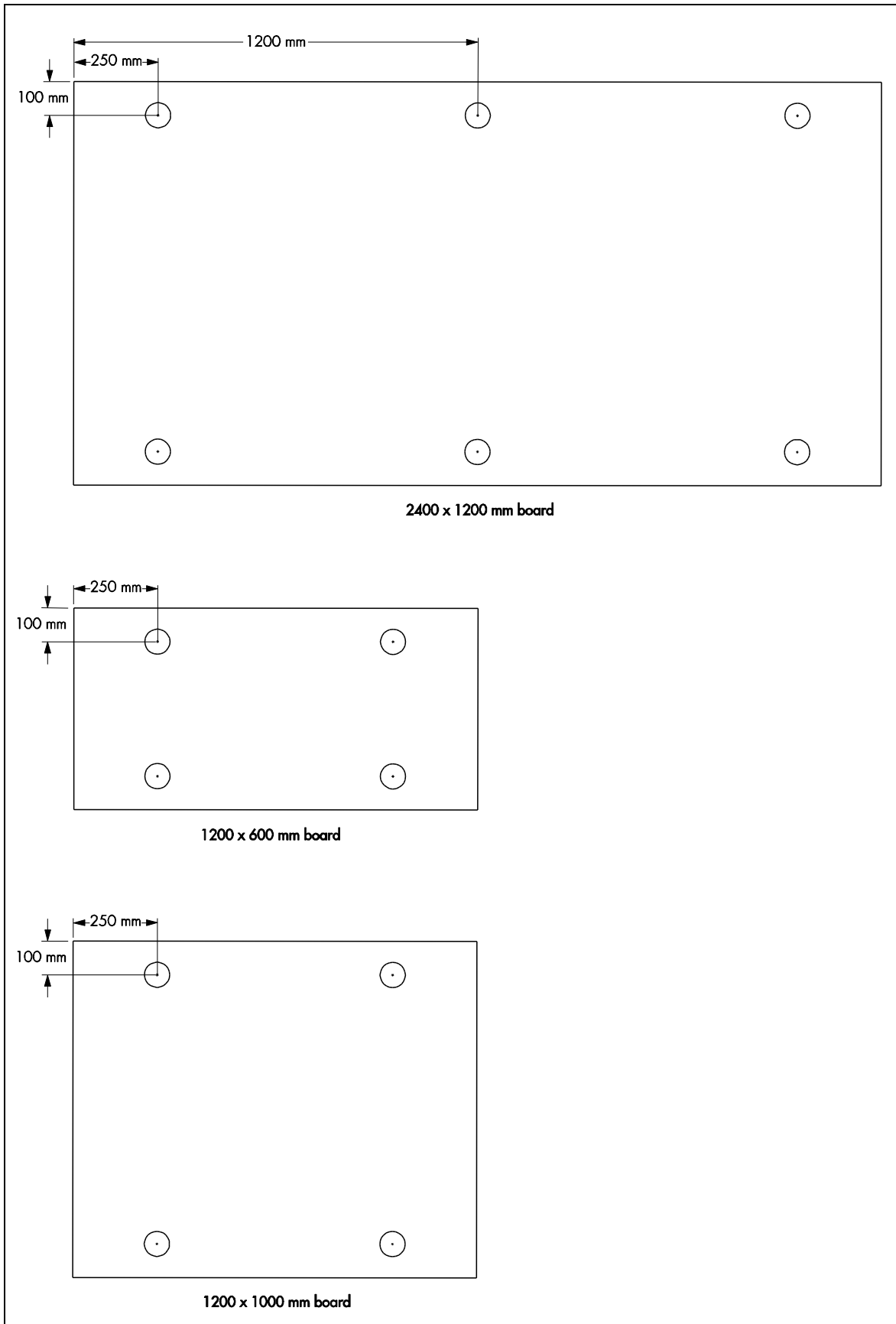

Adhered roofing system applications

13.4 A bonded bituminous VCL should be laid, with 75 mm minimum sealed laps. The VCL should be turned up around the insulation and sealed to the waterproof finish at all edges and penetrations such as rooflights. Advice may be sought from the Certificate holder.

13.5 The product is laid over the VCL in a break-bonded pattern. On profiled metal decks, the long edges of the board should be laid at right angles to the ribs and all board ends must be fully supported on a rib. Boards are secured by the use of a high performance roofing insulation bonding adhesive in accordance with the Certificate holder's recommendations.

13.6 A cold applied waterproofing membrane is then adhered or bonded to the insulation, or mechanically fastened through the insulation into the deck, with joints overlapped prior to the sealing of the joint, in accordance with the manufacturer's instructions and the relevant Agrément Certificate.

Figure 2 Concrete deck

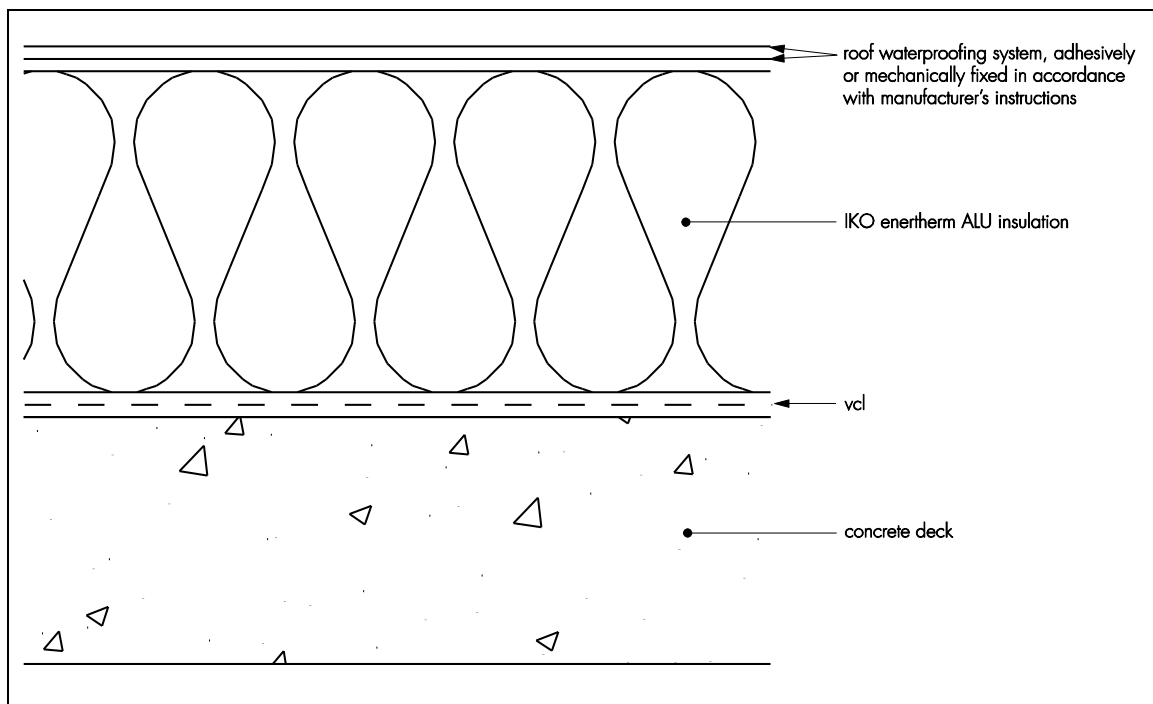

Figure 3 Metal deck

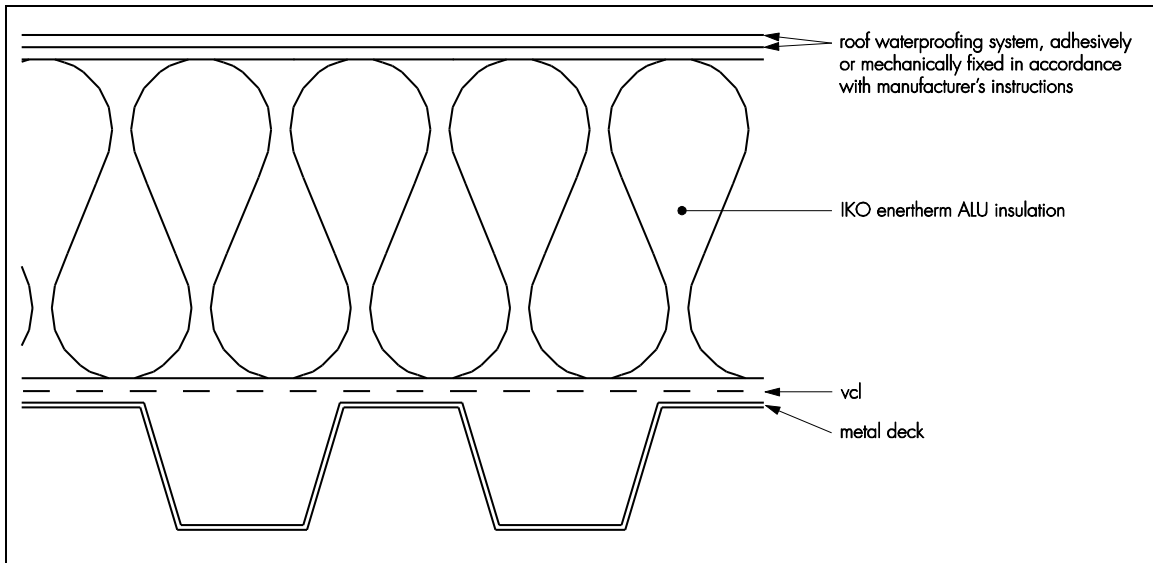
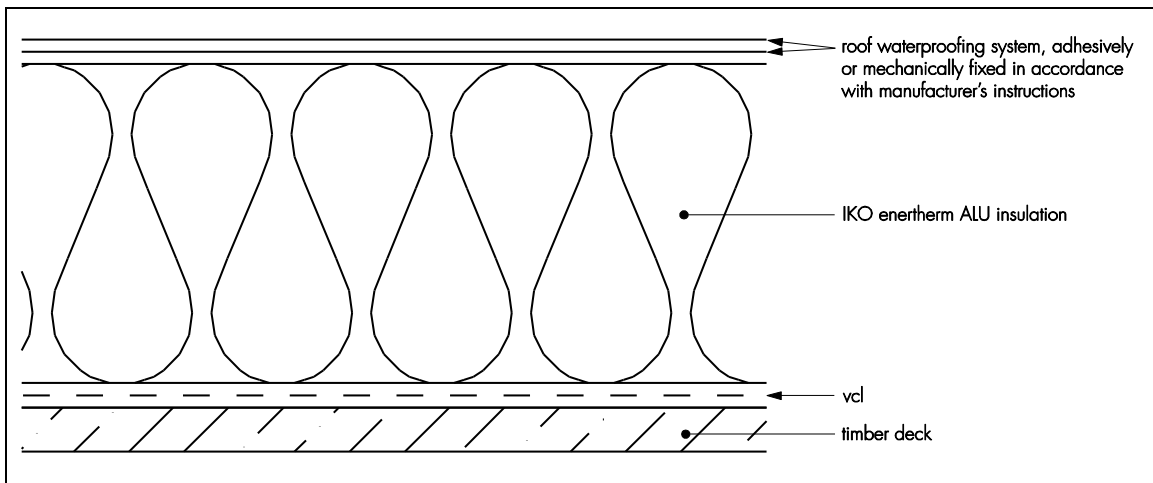

Figure 4 Timber deck



14 Tests

An examination was made of data relating to:

- fire rating
- thermal conductivity
- compressive stress at 10% deformation
- dimensional accuracy
- diffusion tight property of facings
- water vapour resistance
- wind uplift.

15 Investigations

15.1 A condensation risk analysis was carried out.

15.2 A series of U value calculations were carried out.

15.3 The manufacturing process was evaluated, including the methods adopted for quality control, and details were obtained of the quality and composition of the materials used.

Bibliography

BS 5250 : 2011 *Code of practice for control of condensation in buildings*

BS 6229 : 2003 *Flat roofs with continuously supported coverings — Code of practice*

BS 8217 : 2005 *Reinforced bitumen membranes for roofing — Code of practice.*

BS 8747 : 2007 *Reinforced bitumen membranes (RBMs) for roofing — Guide to selection and specification*

BS EN 1991-1-4 : 2005 *Eurocode 1 — Actions on structures — General actions — Wind actions*

BS EN 13165 : 2012 *Thermal insulation products for buildings — Factory made rigid polyurethane foam (PU) products — Specification*

BS EN 13501-1 : 2007 *Fire classification of construction products and building elements — Classification using test data from reaction to fire tests*

BS EN 13501-5 : 2007 *Fire classification of construction products and building elements — Classification using data from external fire exposure to roofs tests*

BS EN 13956 : 2012 *Flexible sheets for waterproofing — Plastic and rubber sheets for roof waterproofing. Definitions and characteristics.*

BS EN ISO 6946 : 2007 *Building components and building elements — Thermal resistance and thermal transmittance — Calculation method*

BS EN ISO 14001 : 2004 *Environmental management systems — Requirements with guidance for use*

BRE Report (BR 262 : 2002) *Thermal insulation: avoiding risks*

BRE Report (BR 443 : 2006) *U-value conventions in practice*

16 Conditions

16.1 This Certificate:

- relates only to the product/system that is named and described on the front page
- is issued only to the company, firm, organisation or person named on the front page – no other company, firm, organisation or person may hold claim that this Certificate has been issued to them
- is valid only within the UK
- has to be read, considered and used as a whole document – it may be misleading and will be incomplete to be selective
- is copyright of the BBA
- is subject to English Law.

16.2 Publications, documents, specifications, legislation, regulations, standards and the like referenced in this Certificate are those that were current and/or deemed relevant by the BBA at the date of issue or reissue of this Certificate.

16.3 This Certificate will remain valid for an unlimited period provided that the product/system and its manufacture and/or fabrication, including all related and relevant parts and processes thereof:

- are maintained at or above the levels which have been assessed and found to be satisfactory by the BBA
- continue to be checked as and when deemed appropriate by the BBA under arrangements that it will determine
- are reviewed by the BBA as and when it considers appropriate.

16.4 The BBA has used due skill, care and diligence in preparing this Certificate, but no warranty is provided.

16.5 In issuing this Certificate the BBA is not responsible and is excluded from any liability to any company, firm, organisation or person, for any matters arising directly or indirectly from:

- the presence or absence of any patent, intellectual property or similar rights subsisting in the product/system or any other product/system
- the right of the Certificate holder to manufacture, supply, install, maintain or market the product/system
- actual installations of the product/system, including their nature, design, methods, performance, workmanship and maintenance
- any works and constructions in which the product/system is installed, including their nature, design, methods, performance, workmanship and maintenance
- any loss or damage, including personal injury, howsoever caused by the product/system, including its manufacture, supply, installation, use, maintenance and removal
- any claims by the manufacturer relating to CE marking.

16.6 Any information relating to the manufacture, supply, installation, use, maintenance and removal of this product/system which is contained or referred to in this Certificate is the minimum required to be met when the product/system is manufactured, supplied, installed, used, maintained and removed. It does not purport in any way to restate the requirements of the Health and Safety at Work etc. Act 1974, or of any other statutory, common law or other duty which may exist at the date of issue or reissue of this Certificate; nor is conformity with such information to be taken as satisfying the requirements of the 1974 Act or of any statutory, common law or other duty of care.